

Notes

1. All dimensions are in millimetres

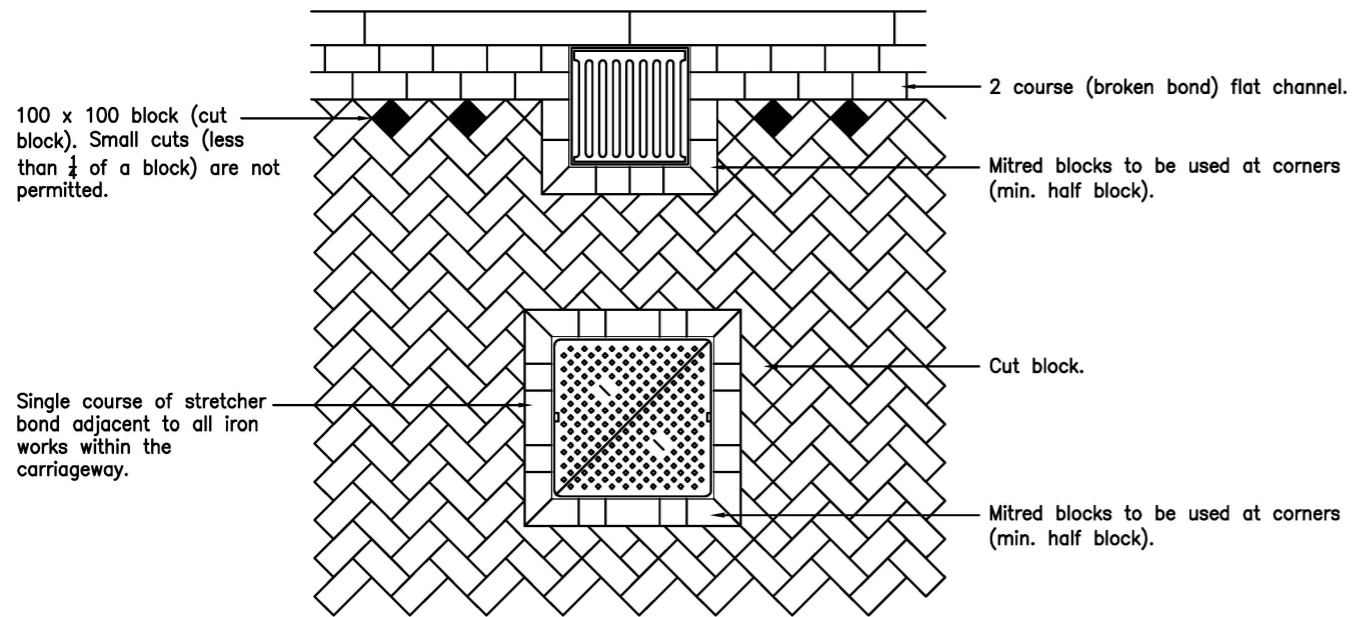

In all block paved areas specifically designed ironworks which allow blocks to be laid up to the frame of gully gratings and manhole covers should be used.

GULLY & MANHOLE COVER DETAIL

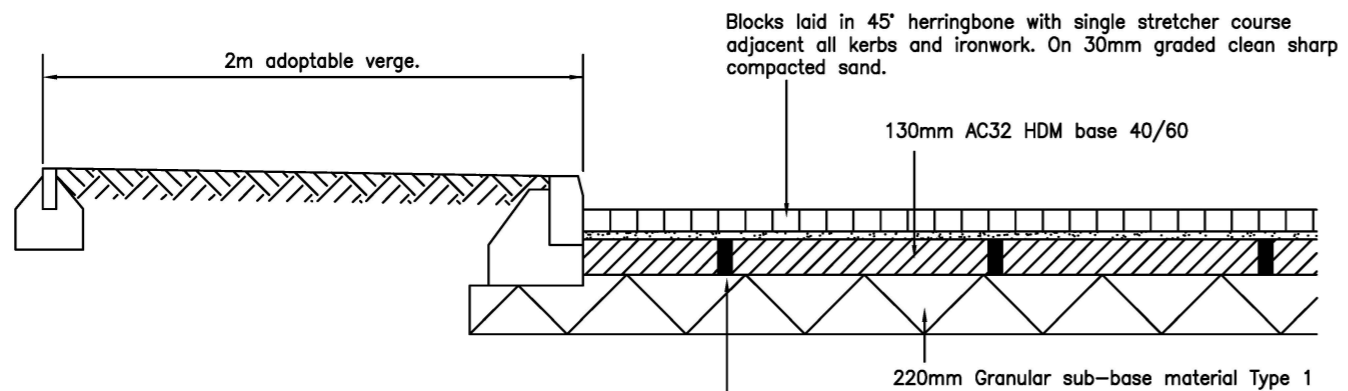

TYPICAL CROSS SECTION

CBR VALUE ON SUB-GRADE	ROAD SUB-BASE	PATH SUB-BASE
>30%	0	0
<=30%	150	150
<=15%	200	150
<=5%	350	150
<=2%	550	300

Do not scale this drawing

A	APR 19	Updated title block	NR
Rev	Date		Checked



Project **STANDARD DRAWINGS**

Title **BLOCK PAVED ROADS**

Drawing No.
SD/900/06A

Scale **N.T.S.** Date **MAR 11**

Department of Place,
Planning & Regeneration