

- Notes
- All dimensions are in millimetres
 - All insitu concrete to foundation and haunch to be GEN 3 concrete
 - Kerb or edging foundation to be laid on rolled sub-base of minimum thickness 100
 - The kerb or edging bed and backing shall normally be laid in one operation
 - Where bed is laid in advance of kerbs 200 x 20 dia mild steel dowel bars will be required in backing at 450 centres and kerbs will be bedded on 10 min mortar designation (i) SHW Series 2400
 - Where granite setts are used horizontal linking bars must be used between dowels
 - Kerbs or edgings shall be laid with dry joints and closely butted to adjacent kerbs and channels
 - Transition kerbs to be used at all changes in kerb face
 - Channel blocks to be used where gradient is flatter than 1:150
 - Cutting of kerbs and channels shall be by approved mechanical means
 - The length of any kerb, edging or channel shall not be less than 300
 - Where channel blocks are laid to false falls the kerb face must be 100 min - 150 max
 - Blockwork kerbs shall be approved by the Director
 - Granite setts in paved areas shall be laid with staggered joints
 - Open joints between granite setts shall be pointed with granolithic mortar, designation (i) SHW Series 2400
 - Timber edging and pegs shall be pressure treated in accordance with SHW Clause 311. Timber pegs shall be 50x50x600 fixed at 900 centres. Double pegs to be used at joints. 2No. galvanised 68mm nails per peg
 - To allow drainage on cycletracks constructed with demarcation paving blocks, gaps shall be left every 10-15 m and at low points. The gaps shall consist of a pair of stop end blocks.
 - Stop end blocks shall be used at the start and end of cycletracks using demarcation paving blocks
 - Conservation kerbs & edgings to be silver grey as manufactured by Marshalls Ltd (or equivalent approved product).

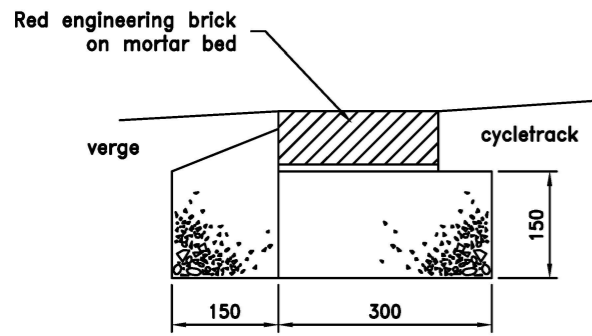

**BRICK EDGING
CYCLETRACK**

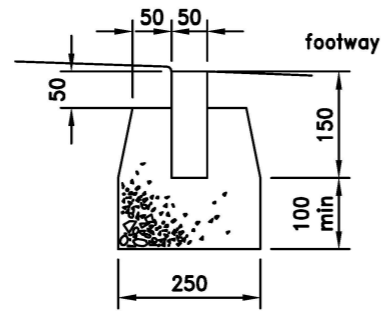

**SQUARE EDGING
EF EDGING**

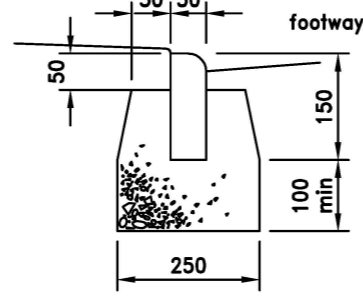

**BULLNOSE EDGING
EBN EDGING**

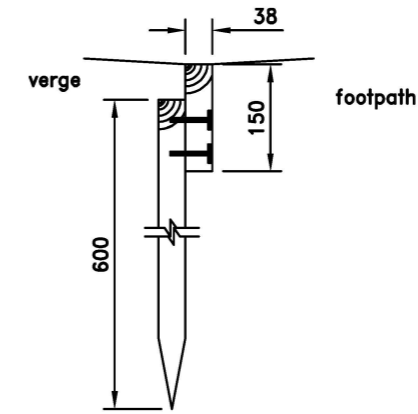

**TIMBER EDGING
TE1 EDGING**
See Note 16

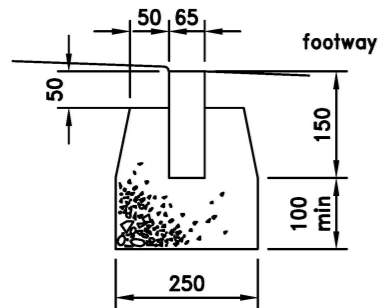

**CONSERVATION EDGING
CE EDGING**
See Note 19

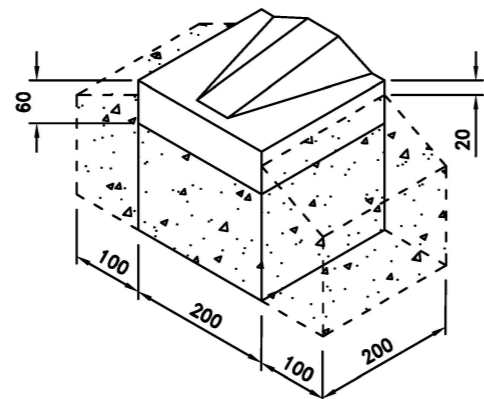

**CYCLETRACK DEMARCATION
STOP END PAVING BLOCK**
(see note 18)

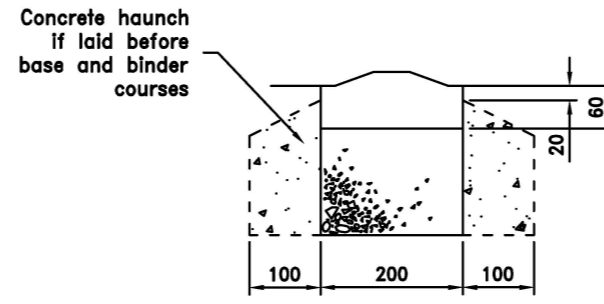

**CYCLETRACK DEMARCATION
PAVING BLOCKS**
(see note 17)

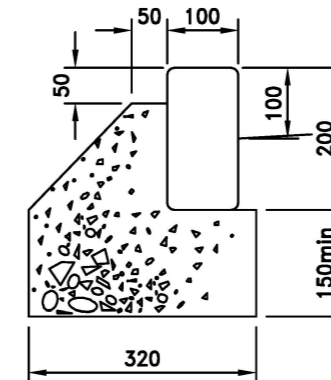

**GRANITE SETT
DS2**

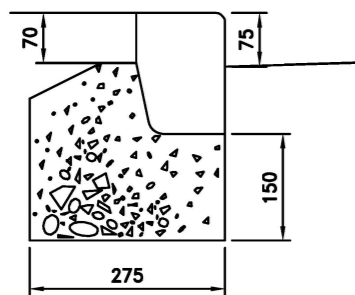

MARSHALLS KEYLINE KERB

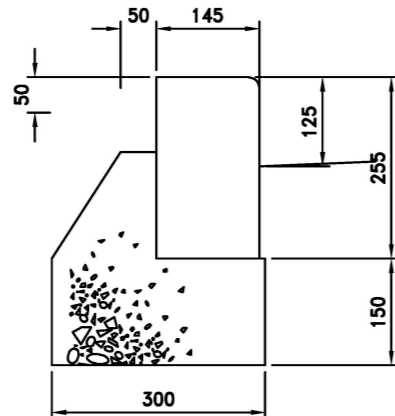

**CONSERVATION KERB
CK1 KERB**
See Note 19

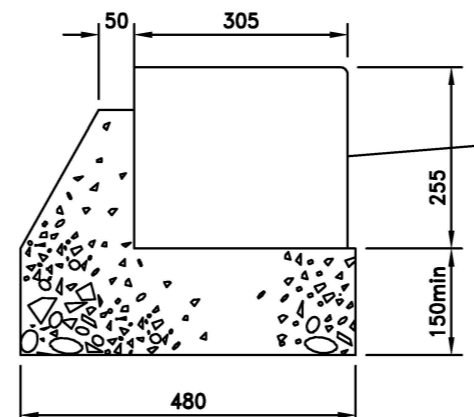

**CONSERVATION QUADRANT
CK2 KERB**
See Note 19

Do not scale this drawing

C	APR 19	Updated title block	NR
B	MAY 13	Various minor amendments	KPT
A	MAR 11	Various minor amendments	KPT
Rev	Date		Checked



Project **STANDARD DRAWINGS**

Title **KERBS, CHANNELS AND EDGING
FOOTWAYS, CYCLETRACKS, ACCESSWAYS & RURAL AREAS**

Drawing No. **SD/1100/02C**
Scale **NOT TO SCALE** Date **MAY 04**
**Department of Place,
Planning & Regeneration**