

- Notes
1. All dimensions are in millimetres
  2. Foundation size for porcupine walling is given as a guide and should be designed to ensure suitable factors of safety against overturning and bearing stress.
  3. Foundations for porcupine walling is to be laid level to ensure any irregularity does not show in the finished wall.
  4. Porcupine blocks are to be laid in accordance with the manufacturers recommendations.
  5. Blocks are to be laid in a stretcher bond pattern with a gap of approximately 5mm between adjacent blocks.

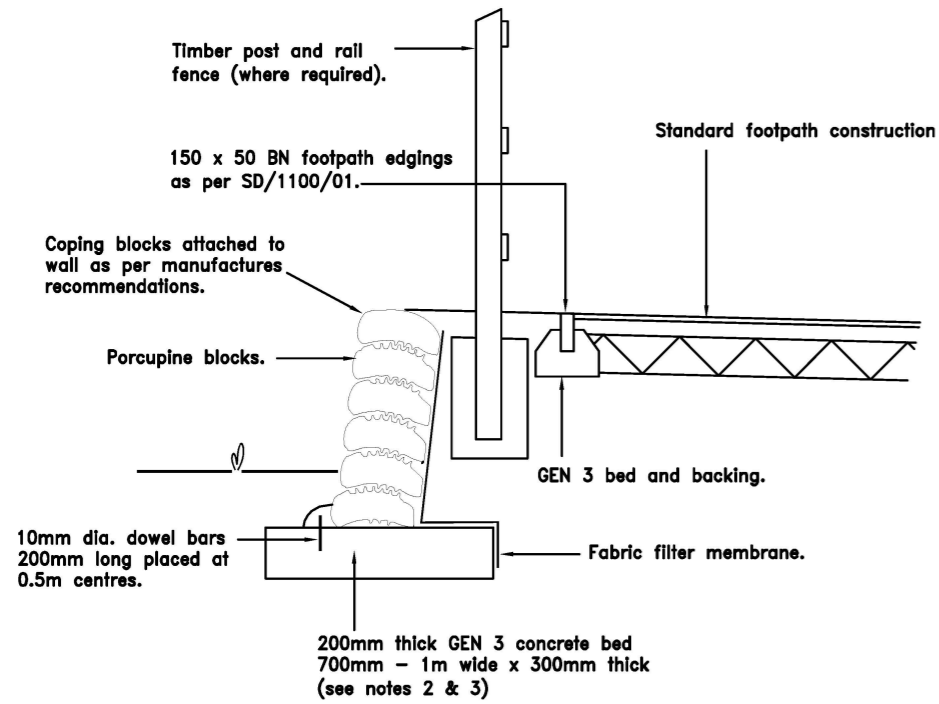

PORCUPINE WALL TYPE A

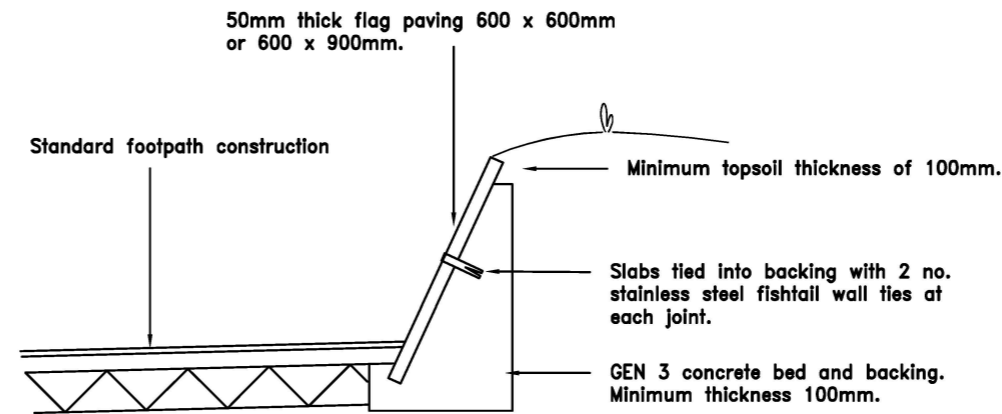

PAVING SLAB RETAINING WALL

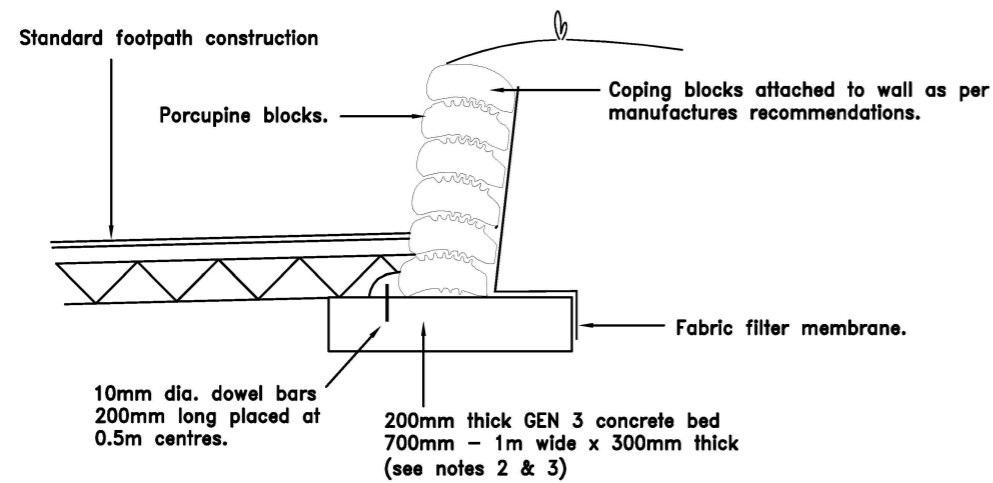

PORCUPINE WALL TYPE B

Do not scale this drawing

B	APR 19	Updated title block	NR
A	JUN 13	Concrete grade revised	KPT
Rev	Date		Checked



Project  
**STANDARD DRAWINGS**

Title  
**LOW RETAINING WALLS**

Drawing No.  
**SD/400/03B**

Scale 1:20 Date Mar 11

Department of Place,  
Planning & Regeneration