

Drawing Number  
**SD/1200/05B**

Notes

1. Cycle parking should be located as close to destinations as possible without interfering with pedestrian traffic and where visual supervision, lighting and shelter from inclement weather can be achieved.
2. Preferred finish for cycle stands are stainless steel, galvanised or ferrocast.

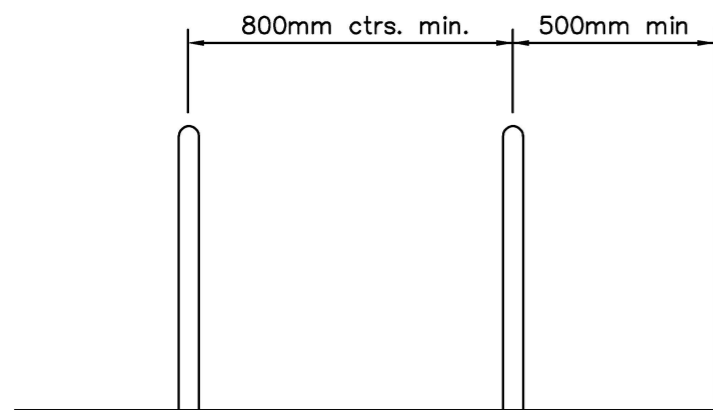
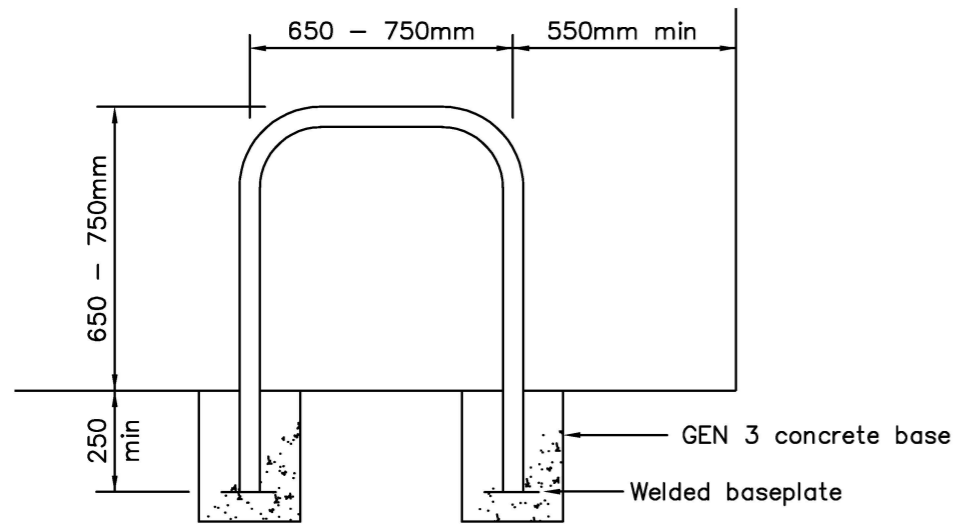

ELEVATIONS

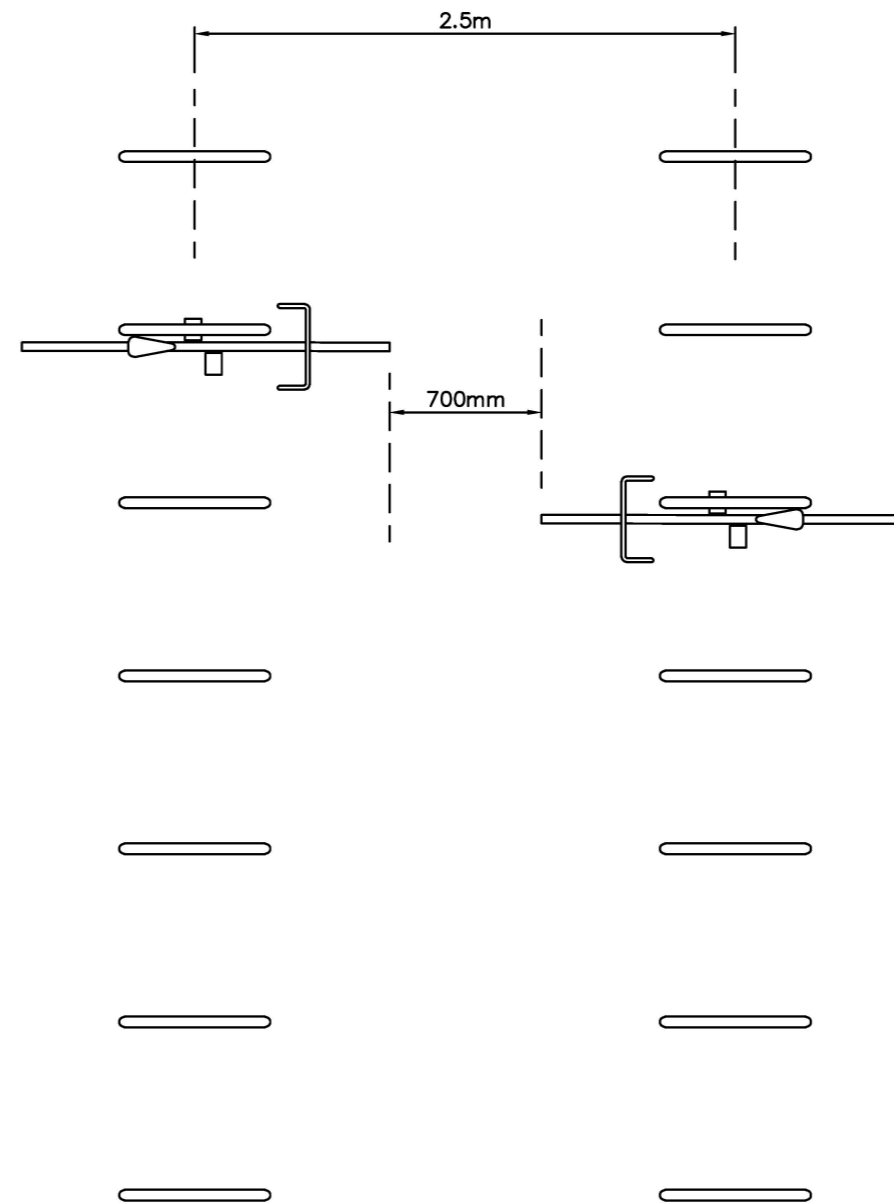

LAYOUT SHOWING MINIMUM SPACING

Do not scale this drawing

Rev	Date	Description	Checked
B	APR 19	Updated title block	NR
A	MAY 13	Concrete grade revised.	KPT



Project  
**STANDARD DRAWINGS**

Title  
**SHEFFIELD CYCLE STANDS**

Drawing No.  
**SD/1200/05B**

Scale **NOT TO SCALE** Date **MAR 11**

Department of Place,  
Planning & Regeneration